



# Alfa Laval AQ1

## AlfaQ™ AHRI-certified plate heat exchanger

### Applications

General heating and cooling duties. Heating by means of steam.

### Standard design

The plate heat exchanger consists of a pack of corrugated metal plates with portholes for the passage of the two fluids between which heat transfer will take place.

The plate pack is assembled between a fix frame plate and a movable pressure plate and compressed by tightening bolts. The plates are fitted with a gasket which seals the interplate channel and directs the fluids into alternate channels. The number of plates is determined by the flow rate, physical properties of the fluids, pressure drop and temperature program. The plate corrugations promote fluid turbulence and support the plates against differential pressure.

The plate and the pressure plate are suspended from an upper carrying bar and located by a lower guiding bar.

Connections are located in the frame plate or, if either or both fluids make more than a single pass within the unit, in the frame and pressure plates.

### Typical capacities

#### Liquid flow rate

Up to 4 kg/s (60 gpm), depending on media, permitted pressure drop and temperature program.

#### Plate types

AQ1, AQ1D - double wall plates

#### Frame types

FG

#### Water heating by steam

50 to 250 kw

### Working principle

Channels are formed between the plates and the corner ports are arranged so that the two media flow through alternate channels. The heat is transferred through the plate between the channels, and complete counter-current flow is created for highest possible efficiency. The corrugation of the plates provides the passage between the plates, supports each plate against the adjacent one and enhances the turbulence, resulting in efficient heat transfer.

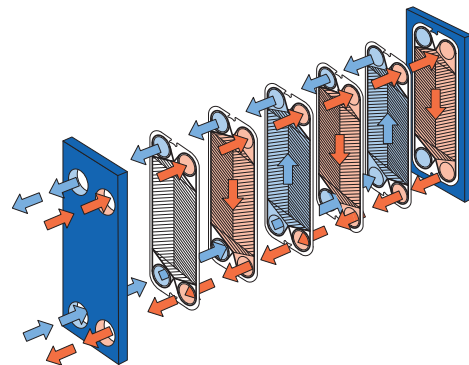
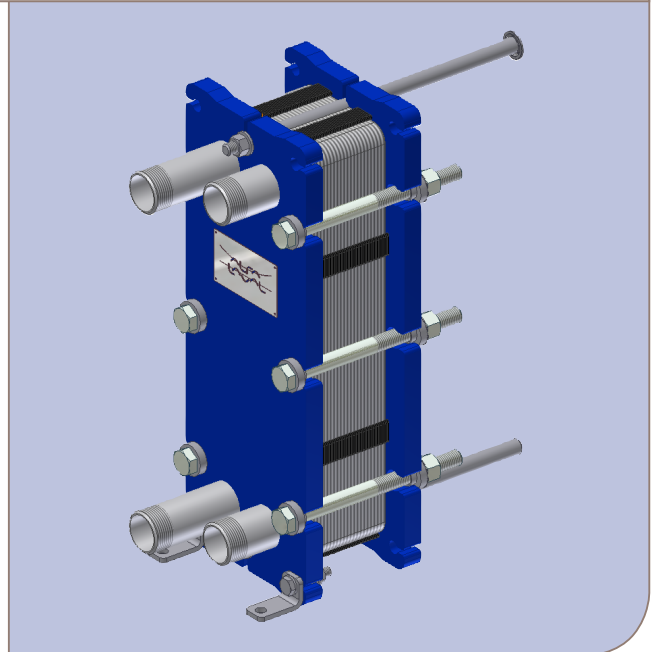

Flow principle of a plate heat exchanger

## STANDARD MATERIALS

### Frame plate

Mild steel, Epoxy painted

### Nozzles

Carbon steel

Pipe: Stainless steel, Titanium

### Plates

Stainless steel Alloy 316, Titanium

### Gaskets (Clip-on)

Nitrile, EPDM, Viton®

Other grades and material available on request.

## TECHNICAL DATA

### Pressure vessel codes PED, ASME, pvcALS™

### Mechanical design pressure (g) / temperature

FG PED, pvcALS™ 1.6 MPa / 180°C

FG ASME 150 psig / 350°F

### Maximum heat transfer surface

3.9 m<sup>2</sup> (40 sq. ft)

### Connections

FG	PED	Size 1¼"	Pipe, thread ISO-R 1¼"
FG	pvcALS™	Size 1¼"	Pipe, thread ISO-R 1¼"
FG	pvcALS™	Size 1¼"	Internal thread ISO-G 1¼", carbon steel
FG	ASME	Size 1¼"	Pipe, thread NPT 1¼"

### Particulars required for quotation

- Flow rates or heat load
- Temperature program
- Physical properties of liquids in question (if not water)
- Desired working pressure
- Maximum permitted pressure drop
- Available steam pressure

## Dimensions

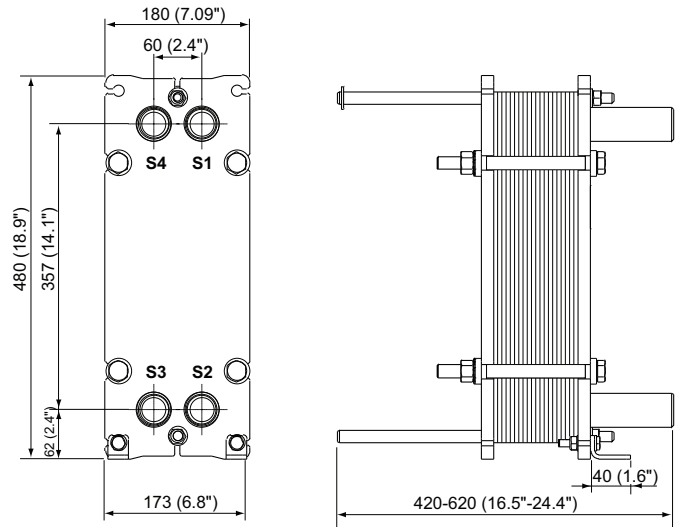

## Measurements mm (inch)

The number of bolts may vary depending on pressure rating.

The thermal performance is third party certified through the AHRI Liquid to Liquid Heat Exchangers certification program



### How to contact Alfa Laval

Up-to-date AlfaLaval contact details for all countries are always available on our website on [www.alfalaval.com](http://www.alfalaval.com)