



Alfa Laval MultiJet 25

Fast, Effective Impact Cleaning

Application

The Toftejorg MultiJet 25 rotary jet head provides 3D indexed impact cleaning over a defined time period. It is ideal for applications where cost-effective impact cleaning with rotary jet heads is needed, but where compliance with hygienic design standards is not a requirement. The device is suitable for process, storage and transportation tanks between 15 and 150 m³. It is designed to work under conditions where finer particles, etc. in the cleaning media may be re-circulated through the machine.

Working principle

The flow of the cleaning fluid makes the nozzles perform a geared rotation around the vertical and horizontal axes. In the first cycle, the nozzles lay out a coarse pattern on the tank surface. The subsequent cycles gradually make the pattern more dense, until a full pattern is reached after 8 cycles.

TECHNICAL DATA

Lubricant: Self-lubricating with the cleaning fluid
 Max throw length: 9 - 14 m
 Impact throw length: 4 - 8 m

Pressure

Working pressure: 3 - 8 bar
 Recommended pressure: 5 - 6.5 bar

Cleaning Pattern

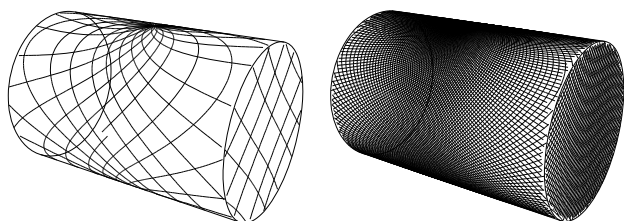

First cycle

Full pattern

The above drawings show the cleaning pattern achieved on a cylindrical horizontal vessel. The difference between the first cycle and the full pattern represents the number of additional cycles available to increase the density of the cleaning.

Certificates

2.1 material certificate and ATEX.



PHYSICAL DATA

Materials

316L (UNS S31603), Duplex steel (UNS N31803), Duplex steel (UNS S 21800), EPDM*, PEEK*, PVDF*, PFA*

* FDA compliance 21CFR§177

Surface finish: Exterior finish: Glass blasted

Temperature

Max. working temperature: 95°C

Max. ambient temperature: 140°C

Weight: 5.1 kg

Connections

Standard female thread: 1" Rp (BSP) or NPT

Caution

Avoid hydraulic shock, hard and abrasive particles in the cleaning liquid, as this can cause increased wear and/or damage of internal mechanisms. In general, a filter in the supply line is recommended. Do not use for gas evacuation or air dispersion. For steaming we refer to the manual.



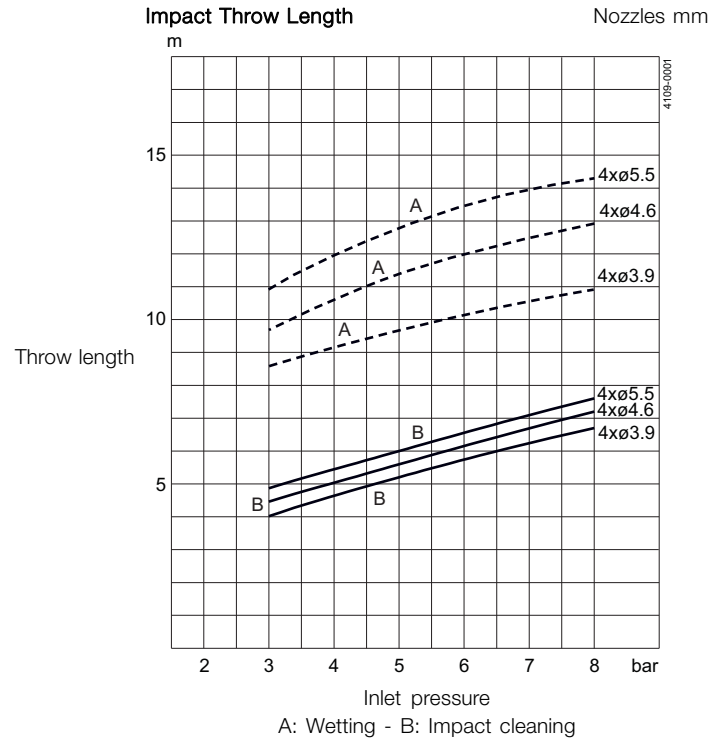
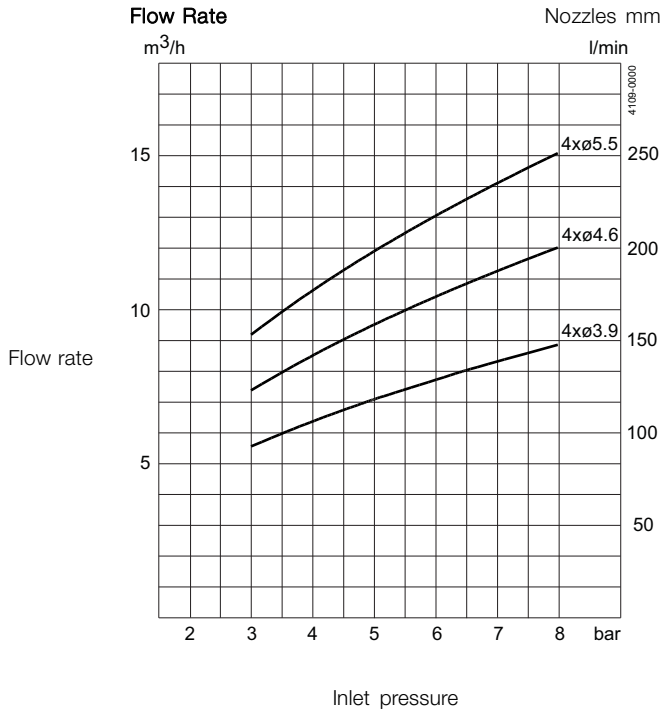

Dimensions (mm)

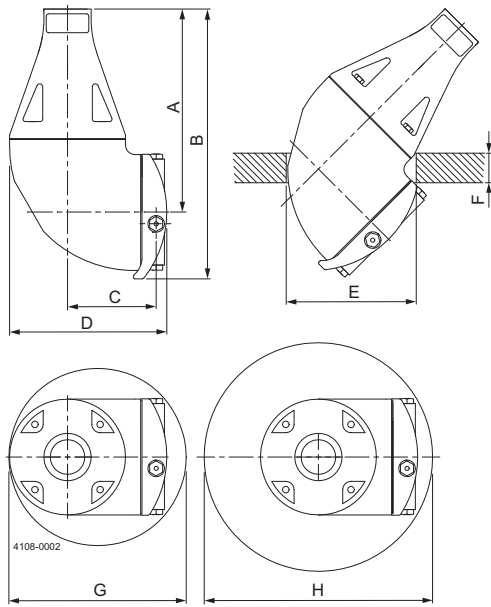

Cleaning Time, Complete Pattern

Min. RPM of machine body
PTM (Pattern time minutes)

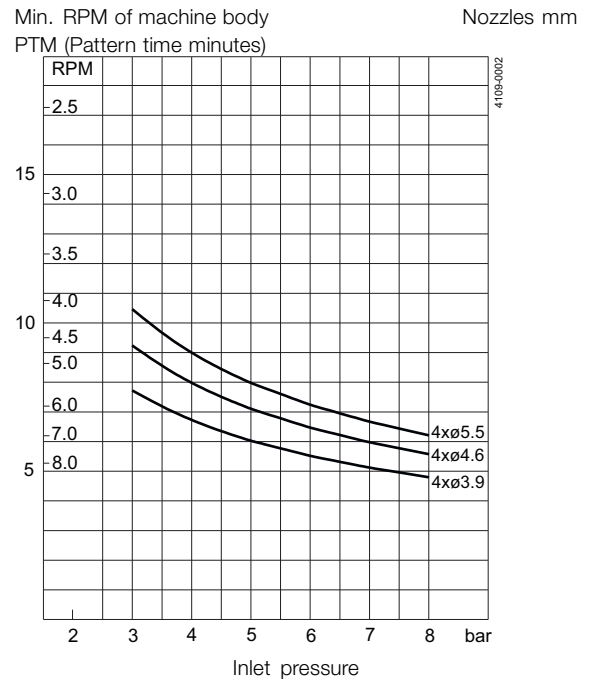

A	B	C	D	E	F	G	H
173	230	75	133	Ø110	max. 25	Ø150	Ø200

Standard Design

The choice of nozzle diameters can optimise jet impact length and flow rate at the desired pressure. The Toftejorg MultiJet 25 is also available with PEEK impeller. A welding adaptor with sealing for 1" ISO, 1" ANSI, 1 1/2" ISO Dairy Pipe or 1 1/2" SWG Pipe is available as an accessory.

TRAX simulation tool

TRAX is a unique software that simulates how the Toftejorg MultiJet 25 performs in a specific tank or vessel. The simulation gives information on wetting intensity, pattern mesh width and cleaning jet velocity. This information is used to determine the best location of the tank cleaning machine and the correct combination of flow, time and pressure to implement.

A TRAX demo containing different cleaning simulations covering a variety of applications can be used as reference and documentation for tank cleaning applications. A TRAX simulation is free and available upon request.

Wetting Intensity

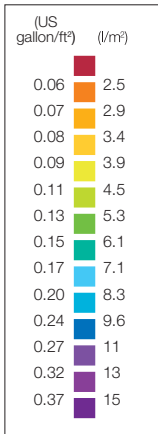

TD 523-208

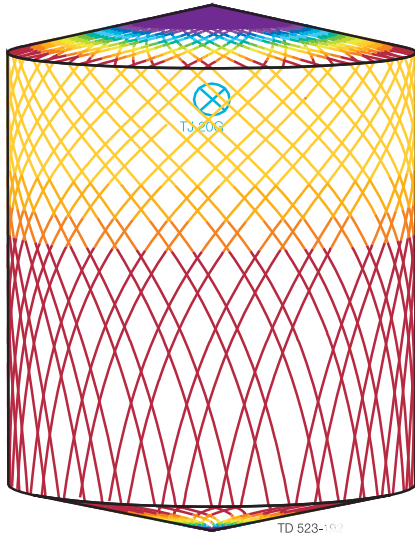

TD 523-192

D4.6m H5.5m, Toftejorg MultiJet 25. 4 x \varnothing 5.5 mm, Time = 2.08 min., Water consumption = 403 l

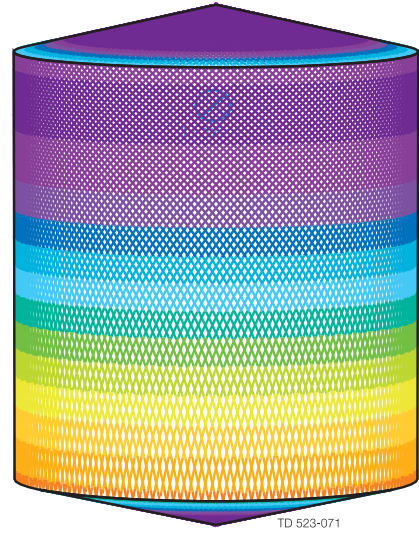

TD 523-071

D4.6m H5.5m, Toftejorg MultiJet 25. 4 x \varnothing 5.5 mm, Time = 8.3 min., Water consumption = 1612 l

Alfa Laval reserves the right to change specifications without prior notification.

How to contact Alfa Laval

Contact details for all countries
are continually updated on our website.
Please visit www.alfalaval.com to
access the information direct.