



Alfa Laval LKC UltraPure

Control/Check valves

Introduction

The Alfa Laval LKC UltraPure Non-return Valve is a hygienic one-way check valve for use in various processes throughout the high-purity industry to prevent reverse flow. It is easy to install, ensuring safety and high product quality.

Application

The LKC UltraPure Non-return Valve is designed for single directional product flow, meeting the demands of high-purity applications across the biotechnology, pharmaceutical and personal care industries.

Benefits

- Highly reliable, self-acting valve
- Easy to install
- Protects process equipment
- Prevents reverse flow
- Full transparency and traceability of the entire supply chain due to the Alfa Laval Q-doc documentation package

Standard design

The Alfa Laval LKC UltraPure Non-return Valve consists of a valve body in two parts, valve plug and spring, assembled by means of a clamp ring and hygienically sealed with a special seal ring. A guide disc with four legs ensure alignment of the spring-loaded valve plug with an o-ring seal. The valve is available with weld and clamp ends for ISO and DIN tubing connections.

Working principle

The Alfa Laval LKC UltraPure Non-return Valve opens and closes depending on the pressure. The spring acts on the valve plug and keeps the valve closed until the force from the pressure in the inlet exceeds the force of the spring. If a reverse flow should occur, the spring force and the pressure from the outlet will keep the valve closed. Required differential pressure for opening the valve when fitted in a vertical pipe is approximately 6 kPa (0.06 bar).

Certificates



TECHNICAL DATA

Max. product pressure: 1000 kPa (10 bar)

Required differential pressure for opening the valve when fitted in a vertical pipe, as shown in fig. 2, is approx. 6 kPa (0.06 bar).

Surface specification (Product wetted steel parts)

Internal:	Ra < 0.8 µm
ASME BPE designation:	SF3
External:	Ra < 0.8 µm
Internal:	Ra < 0.5 µm
ASME BPE designation:	SF1
External:	Ra < 0.8 µm

PHYSICAL DATA

Product wetted steel part	1.4404 (316L) Acc. to EN 10088 or equal (AISI 316L)
Other steel parts	1.4301 (304) Acc. to AISI 304
Spring	Electropolished

Elastomers

Product wetted elastomer	EPDM Acc. to FDA and USP Class VI Temperature: -10°C - 140°C
Product wetted elastomer	FPM Acc. to FDA Temperature: -10°C - 180°C

Connections

Weld ends	Matching tubes and fittings: ISO 2037 / Series A/DIN Acc. to ISO or DIN
Clamp ends	Matching tubes and fittings: ISO 2037 / Series A/DIN Acc. to ISO or DIN

Pressure drop/capacity diagrams

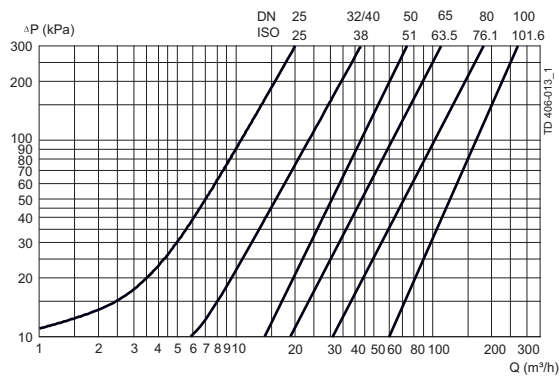

Fig.1. **Notel**

For the diagram the following applies:

Medium: Water (20°C).

Measurement: In accordance with VDI 2173.

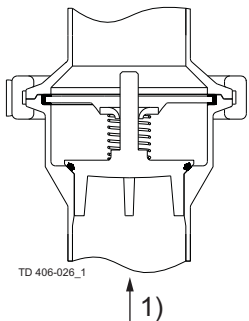

Fig.2.
 1 = Flow direction.
 Shows the optimal built-in situation to make sure the valve is drainable. The four guide legs of the valve cone ensure good alignment. 90° rotation.

Dimensions (mm)

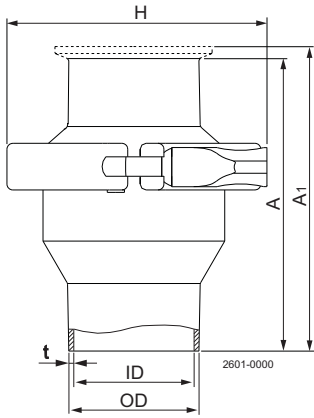

Table 1. Dimensions (mm)

Size	ISO						DIN						
	25	38	51	63.5	76.1	101.6	25	32	40	50	65	80	100
A	62.5	75.0	87.5	95.0	115.0	155.0	62.5	75.0	75.0	87.5	95.0	115.0	155.0
A ₁	105.5	118.0	130.5	138.0	158.0	198.0	105.5	118.0	118.0	130.5	151.0	171.0	211.0
OD	25.4	38.4	51.4	63.9	76.4	102.0	30.0	36.0	42.0	54.0	70.0	85.0	104.0
ID	22.5	35.5	48.5	60.5	72.0	97.6	26.0	32.0	38.0	50.0	66.0	81.0	100.0
t	1.45	1.45	1.45	1.7	2.2	2.2	2.0	2.0	2.0	2.0	2.0	2.0	2.0
H	77.4	90.4	103.6	132.6	144.0	164.0	77.4	90.4	90.4	103.6	132.6	144.0	164.0
Weight (kg):													
Welding ends	0.7	1.0	1.3	2.1	2.9	4.3	0.7	1.0	1.0	1.3	2.1	2.9	4.3
Clamp ends	0.9	1.1	1.4	2.5	3.4	4.7	0.9	1.1	1.1	1.4	2.5	3.4	4.7

Alfa Laval reserves the right to change specifications without prior notification.

How to contact Alfa Laval

Contact details for all countries
are continually updated on our website.
Please visit www.alfalaval.com to
access the information direct.